

Autoignition of gaseous fuels in various oxidizer volumetric compositions in high temperature

Sebastian Werle*

Institute of Thermal Technology, The Silesian University of Technology, Gliwice, Poland.

Received Date: 11 Jan.; 2011

Accepted: 14 Feb.; 2011

ABSTRACT

The paper presents results of experimental studies on the methane and propane ignition process in various volumetric compositions of oxidizers heated to temperatures higher than ignition point of analyzed fuels (HTAC conditions—High Temperature Air Combustion conditions). The increment of temperature ΔT and the ignition delay time τ_{ig} are parameters characterizing the process of ignition under these conditions. These parameters are functions of equivalence ratio φ , temperature of the oxidizer T_{oxi} and the volumetric composition of oxidizer z_i . In order to achieve the minimum ignition delay time τ_{ig} and the maximum increment of the temperature ΔT , the oxidizer temperature didn't have to be maximized. There is an interval of T_{oxi} in which analyzed the parameters reaching their extreme values.

Keywords

High temperature air combustion, ignition, methane, propane.

1. Introduction

HTAC [1] is the most important achievement of the combustion technology in recent years. This technology is also known as Excess Enthalpy Combustion (EEC) [2] or FLameless OXidation (FLOX) [3] in Germany or MILD (Moderate and Intensive Low-oxygen Dilution) Combustion or Diluted Combustion [4] in Italy.

The basic principles of this technology are as follows [2]:

1. The temperature of oxidizer T_{oxi} has to be higher than the autoignition point T_{au} of the combustible mixture. In such conditions the phenomenon of combustion is in its character similar to a volumetric and flameless combustion. Because of this, the temperature level inside the combustion chamber is relatively uniform, and temperature peaks ($t \geq 1400^\circ\text{C}$) at which thermal nitrogen oxides are formed, can be avoided.

2. The fuel nozzles are positioned away from the air nozzles supplying the gas fuel into hot flame gases.

3. Strong recirculation of hot exhausted gases to reaction chamber is required.

4. HTAC is controlled simultaneously by mixing fuel and the oxidizer and by means of chemical kinetics.

The main advantages of applying HTAC technique are as follows [2]:

1. Because of the strong recirculation of combustion gases, HTAC burners permit to increase the average temperature in the combustion chamber to a more equalized value avoiding temperature peaks and thermal NO_x formation.

2. The intensive circulation of hot combustion gases reduces the local concentration of oxygen, retards mixing of the fuel with the oxidizer, so that the formation of prompt NO_x and via N_2O may be prevented.

3. The heat radiation is more effective.

*Corresponding author: S.Werle (e-mail:sebastian.werle@polsl.pl)

4. The increase of the average temperature in the combustion chamber and the heat radiation improves the thermal efficiency of the system and thus also reduces the consumption of fuels and the emission of NO_x and CO₂. The final results are a reduction of the operating cost.

5. The construction of the combustion chamber is very compact; in comparison with a classical combustion system it is much smaller, due to the fact of the capital costs are not so high.

The HTAC technology has been introduced so far for furnace gas combustion only. Furthermore, it was also proved that in a similar way, it may be used for combustion of liquid fuels [5].

Further on, first trials has been made to burn solid fuels in a chamber of several MW of power with very good results and ultra low NO_x emission [6, 7]. HTAC technology is still a new and promising combustion technology so the HTAC technology is still a subject of scientific research all over the world. The present paper deals with

Table 1. Experimental Matrix

φ	CVB				CFR	
	methane		propane		propane	
	T _{oxi} , K	oxidizer	T _{oxi} , K	oxidizer	T _{oxi} , K	oxidizer
1.43	960, 989, 1005, 1034, 1055, 1085, 1104, 1134, 1186, 1206, 1234	Air	803, 833, 853, 883, 903, 933, 960, 989, 1005, 1034, 1186	Air	803, 833, 853, 883, 903	Air
		Oxidizer 1		Oxidizer 1		
		Oxidizer 2		Oxidizer 2		
1.25	960, 989, 1005, 1034, 1055, 1085, 1104, 1134, 1186, 1206, 1234	Air	803, 833, 853, 883, 903, 933, 960, 989, 1005, 1034, 1055	Air	803, 833, 853, 883, 903	Air
		Oxidizer 1		Oxidizer 1		
		Oxidizer 2		Oxidizer 2		
1.11	960, 989, 1005, 1034, 1055, 1085, 1104, 1134, 1186, 1206, 1234	Air	803, 833, 853, 883, 903, 933, 960, 989, 1005, 1034, 1055	Air	803, 833, 853, 883, 903	Air
		Oxidizer 1		Oxidizer 1		
		Oxidizer 2		Oxidizer 2		
1.00	960, 989, 1005, 1034, 1055, 1085, 1104, 1134, 1186, 1206, 1234	Air	803, 833, 853, 883, 903, 933, 960, 989, 1005, 1034, 1055	Air	803, 833, 853, 883, 903	Air
		Oxidizer 1		Oxidizer 1		
		Oxidizer 2		Oxidizer 2		
0.91	960, 989, 1005, 1034, 1055, 1085, 1104, 1134, 1186, 1206, 1234	Air	803, 833, 853, 883, 903, 933, 960, 989, 1005, 1034, 1055	Air	803, 833, 853, 883, 903	Air
		Oxidizer 1		Oxidizer 1		
		Oxidizer 2		Oxidizer 2		
0.77	960, 989, 1005, 1034, 1055, 1085, 1104, 1134, 1186, 1206, 1234	Air	803, 833, 853, 883, 903, 933, 960, 989, 1005, 1034, 1055	Air	803, 833, 853, 883, 903	Air
		Oxidizer 1		Oxidizer 1		
		Oxidizer 2		Oxidizer 2		
0.63	960, 989, 1005, 1034, 1055, 1085, 1104, 1134, 1186, 1206, 1234	Air	803, 833, 853, 883, 903, 933, 960, 989, 1005, 1034, 1055	Air	803, 833, 853, 883, 903	Air
		Oxidizer 1		Oxidizer 1		
		Oxidizer 2		Oxidizer 2		
0.50	960, 989, 1005, 1034, 1055, 1085, 1104, 1134, 1186, 1206, 1234	Air	803, 833, 853, 883, 903, 933, 960, 989, 1005, 1034, 1055	Air	803, 833, 853, 883, 903	Air
		Oxidizer 1		Oxidizer 1		
		Oxidizer 2		Oxidizer 2		

the results of experimental investigations concerning the ignition of methane and propane in various volumetric compositions of superheated oxidizer in a combustion chamber with a constant volume (CVB). There were initial results but to create real furnace conditions and compare results achieved on CVB installation, experiments in a co-flow reactor (CFR) were also performed

2. Experiment

The impact of the following variables: type of gaseous fuel, initial temperature of oxidizer T_{oxi} (for methane $T_{oxi}=960\div1234K$ and for propane $T_{oxi}=803\div1055K$), equivalence ratio $\phi=0.50\div1.43$ and volumetric composition of oxidizer ($z_{O_2}=0.05\div0.21$ and $z_{N_2}=0.79\div0.95$) on the ignition process under HTAC conditions were investigated. Full experimental matrix is presented in Table 1. The lowest values of analyzed temperatures from intervals of T_{oxi} are higher than the autoignition temperature of the combustible mixture (see Table 2). This fundamental experimental assumption indicates the main of the requirements of HTAC technique, which demands preheating the oxidizer above autoignition point and strong gas recirculation (low level of volumetric composition of oxygen) into the combustion chamber.

An example of the determination of the increment of temperature ΔT and the way of determining the ignition delay time τ_{ig} are presented in Fig.1. Point "0" is interpreted as the moment of the gas injection and the start of ignition.

The temperature distance between point "0" and the point in which the temperature reaches its maximum is determined as the increment of temperature ΔT .

The time from the moment of opening the electric valve (point "0") to the achievement of the maximum temperature is assumed as the ignition delay time τ_{ig} . The maximal value of standard deviation of increment of temperature ΔT is

Table 2. Main properties of investigated fuels [8]

	Methane	Propane
Chemical formula	CH ₄	C ₃ H ₈
Flammability limits in the air mixtures, % vol.	5.0-15.0	2.0-9.5
Autoignition temperature T_{ai} of the combustible mixture with air, K	868.0	766.0

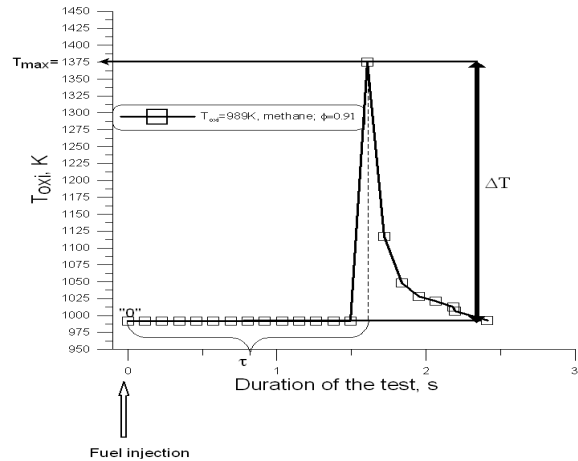

Fig. 1. Example of the increment of the temperature ΔT and the ignition delay time τ_{ig} , as a function of the duration of the test; methane; $T_{oxi}=989K$; $\phi=0.91$.

equal to $\sigma_{\Delta T}=6.22K$ and ignition delay time τ_{ig} is equal to $\sigma_{\tau_{ig}}=0.017s$. The signals from thermocouples were collected every 0.001 s. The oxidizer temperature T_{oxi} was measured with an enlarged uncertainty equal to $\delta T_{oxi}=2K$. The temperature inside the reaction chamber (after gas injection) T_{max} was measured with uncertainty equal to $\delta T_{max}=1.2K$. Error of calculations of the equivalence ratio $\delta\phi$ was equal to $\delta\phi=0.02\%$.

2.1 Experimental rigs-CVB

Figure 2 shows the diagram of the stand for experimental investigations of the ignition of gaseous fuels and its fundamental elements [9]. An experimental cylindrical combustion chamber (2) (CVB) made of steel with a total volume of approximately 400 cm³ was used. The oxidizers

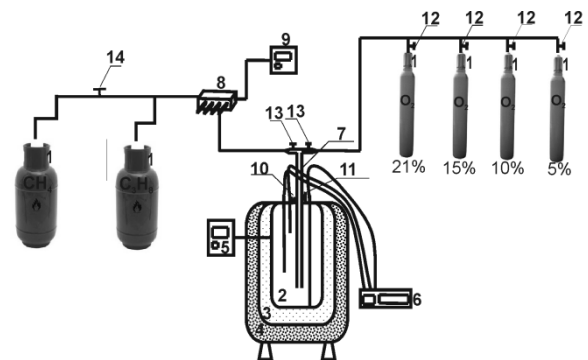

Fig.2. Schematic of constant volume bomb (CVB); 1-gas cylinders, 2-reaction chamber, 3-heating coil, 4- thermal insulation, 5- microprocessor control unit, 6- digital recorder, 7-conduit supplying gas, 8-electric valve, 9-control unit, 10-safety vent, 11 through 14-valves.

in the reaction cylinder were initially heated by heating coils (3) with a total heating power of 1.7 kW. Oxidizers with different oxygen concentrations were taken from gas cylinders (1) equipped with standard reducing valves and valves (12) to cut off the stream of the oxidizer. The combustion chamber is insulated with ceramic fibre (4) by a microprocessor control unit (9)) and the gas supply pipe (7) were injected into the reaction chamber. Fuels at room temperature were injected to the stationary oxidizer. The analyzed gases are switched on and off by opening and closing the valve (14). The gas supply pipe with an internal diameter of 3 mm is equipped with four holes with an internal diameter of 0.5 mm, situated around the axis of the pipe. It is equipped with valves (11) and (13); thus it is possible to adjust the dosage of oxidizer and fuel. In the upper cover, there is a safety vent (10) as well as three holes, through which three thermoelements type S (PtRh10-Pt) are installed and connected with a digital recorder (6). The temperature of the hot oxidizer inside the reaction chamber is controlled by a microprocessor control unit (5) integrated with a thermoelement of the type K (NiCr-NiAl).

Procedure of measurements:

1. The steady oxidizer is electrically heated up to the pre-set constant temperature T_{oxi} .
2. The electric valve is opened (the time of opening is connected with the equivalence ratio).
3. Gas - in amounts corresponding to the equivalence ratio - is passed into the vessel.
4. An ignition of the mixture occurs in the reaction vessel, which is observed by a rise of the temperature registered on the recorder and by a distinct audible explosion inside the vessel.

2.2. Experimental rigs-CFR

The main task of this research was to test the research technology in conditions similar to actual industrial furnaces and to compare the results obtained at different conditions of combustion (CVB and CFR reactors). The tests were performed on a special stand (Fig. 3), consisting of a

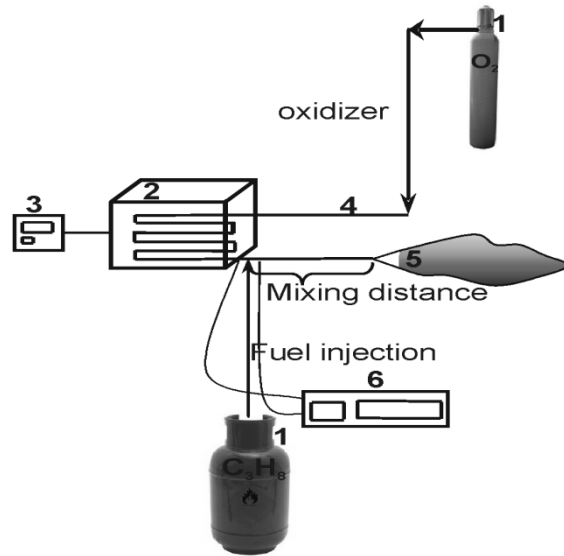

Fig.3. Schematic of co-flow reactor (CFR). 1- fuel/oxidizer cylinders, 2- reactor chamber, 3- microprocessor control unit, 4- stainless steel, spiral tube, 5- flame, 6- digital recorder

ceramic chamber (2), heated by heating coils with a total heating power of 1.7 kW. The temperature inside the reaction chamber is controlled by a microprocessor control unit (3) integrated with a thermoelement of the type K. The reactor chamber is provided with rolled stainless steel, a spiral tube (4) with an internal diameter of 4 mm. The oxidizer (atmospheric air: $z_{\text{O}_2}=0.21$ and $z_{\text{N}_2}=0.79$) taken from the cylinder (1) flows inside the heated pipe and is initially preheated to the pre-set temperature. A stream of gas from the cylinder (1) with room temperature in an amount equal to predicted and controlled value of the equivalence ratio is supplied into the hot flowing oxidizer. Ignition (and the flame (5)) and the increment of the temperature rise on a digital recorder (6) are observed.

The temperature of the mixture after its reaction is measured using two thermoelements type K, situated on both sides of the injection point connected with a digital recorder (6). The final value of the increment of temperature is the result of the arithmetic mean taken from two thermocouples.

3. Results

In Figure 4 the increment of temperature ΔT (upper) and ignition delay time τ_{ig} (lower) as a function of the oxidizer temperature T_{oxi} for both

analyzed fuels and for $\phi=0.91$ is shown. It can be observed for each test that the initial increment of temperature ΔT increases at the beginning with a growth of oxidizer temperature T_{oxi} . It is connected with the relationship that with the growth of the oxidizer temperature T_{oxi} , the reaction rate and frequency of particle collision are both increasing. As it can be observed in this Figure, there is a value of oxidizer temperature T_{oxi} , in which the increment of temperature ΔT reaches its maximum.

As can be observed, for the value of T_{oxi} in which $\Delta T=\Delta T_{max}$, the increment ΔT in the case of propane is higher than in the case of methane. As it is generally known, more complicated chemical complex structure of the propane molecule favors the easier ignition of propane than in methane.

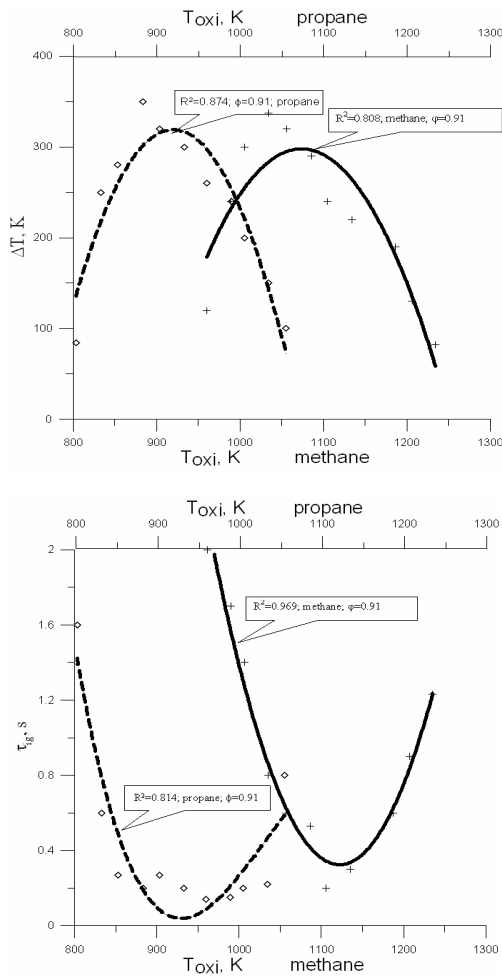

Fig.4. Dependence of increment of temperature ΔT (upper) and ignition delay time τ_{ig} (lower) as a function of oxidizer temperature T_{oxi} (atmospheric air)

Above the value of T_{oxi} in which the increment ΔT reaches its maximum (ΔT_{max}), this parameter is decreasing due to smaller level of density (concentration) of reacting gases at constant pressure (chamber is not hermetic). It can be concluded, that despite the fact that increment of oxidizer temperature ΔT favors the growth of reaction rate, the decrease of gas density is much stronger.

As a result, above the value of T_{oxi} in which $\Delta T=\Delta T_{max}$, this parameter is decreasing. It can be also observed that the ignition delay time τ_{ig} decreases initially with the growth of oxidizer temperature T_{oxi} due to growth of reaction rate and frequency of particle collision. There is a value of temperature oxidizer T_{oxi} , in which the ignition delay time τ_{ig} reaches its minimum. Above this value, there is an observed growth of the ignition delay time τ_{ig} . It is caused mainly due by the same factors like in ΔT analysis. For the value of oxidizer temperature T_{oxi} in which $\tau_{ig}=\tau_{min}$, propane is characterized by lower values of ignition delay time τ_{ig} than methane. Generally it can be concluded that there is a value of temperature of oxidizer T_{oxi} in which increment of temperature ΔT reaches its maximum and simultaneously ignition delay time τ_{ig} reaches its minimum. It seems that preheating oxidizer above this value of temperature, in the case of methane $T_{oxi} \approx 1100$ K and in the case of propane $T_{oxi} \approx 950$ K is unsubstantiated. This opinion is correct when the HTAC technology is considered from a point of view of increment of temperature ΔT and ignition delay time τ_{ig} . Similar diagrams have been plotted for all analyzed (see experiment matrix) values of equivalence ratio but it is well known that most combustion properties have simple maxima or minima in the neighborhood of $\phi=1$. It is worthwhile to emphasize one important feature. Methane and propane as majority of alkanes inhibits its own ignition when rate of chain branching (as essential reaction for the high temperature combustion) is higher than rate of tearing off of chain branching [10]. Hydrogen atoms and alkyl radicals (the most important products of chain branching) in different conditions are characterized by different properties. It can be noticed on Fig. 5, that for rich mixtures ($\phi>1$), alkanes are inhibitors of ignition reaction due to important rerouting of hydrogen atoms from chain branch-

ing reaction. This feature predominates over ignition so ignition delay time increases with growth of ϕ . For lean mixtures ($\phi < 1$), not very often collisions between oxidizing and reducing species (small presence of fuel) are limiting the rerouting of hydrogen atoms (favorable factor). Here alkanes behave like promoters of their own ignition. In this case, ignition delay time decreases with growth of the ϕ . For values ϕ in which τ_{ig} reaches its minimum, there is a balance between amount of reactive radicals and not very well reactive hydrogen atoms.

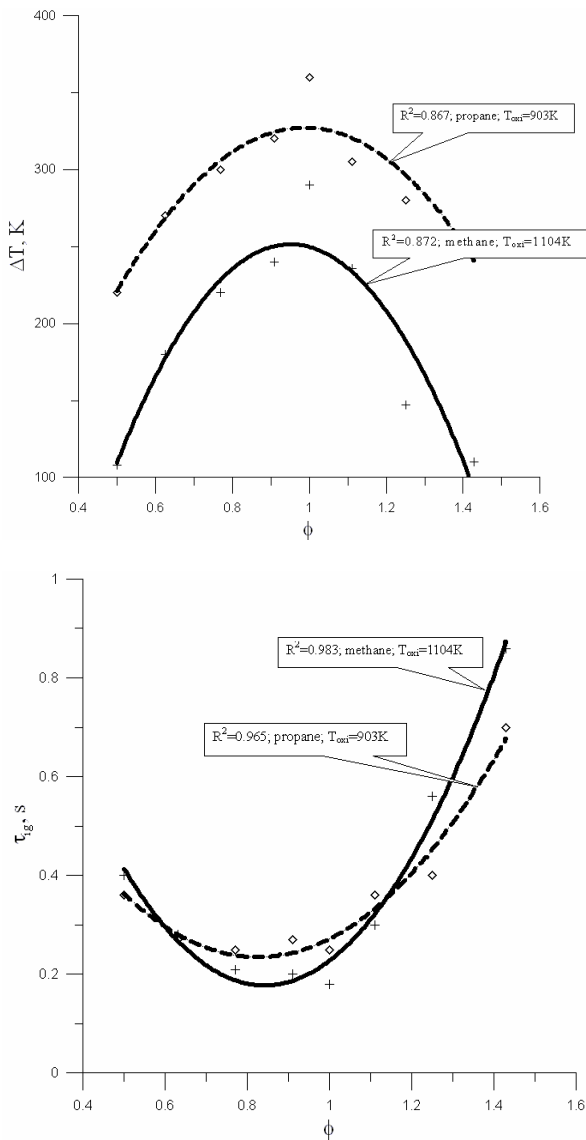

Fig.5. Dependence of increment of temperature ΔT (upper) and ignition delay time τ_{ig} (lower) as a function of equivalence ratio ϕ (atmospheric air)

3.1 CVB versus CFR reactor

Fig. 6 shows comparison of results achieved in CVB and CFR.

It can be observed in this Figure the dependence of increment of temperature ΔT as a function of oxidizer temperature T_{oxi} . It can be clearly noticed that CFR gives possibility to achieve higher values of ΔT , caused by mainly by much higher level of turbulence and higher level of homogeneity of the mixture. Additionally, in CFR there is a lower value (in comparison with CVB) of interval of T_{oxi} in which the increment of temperature reaches its maximum. The results achieved on CFR confirm the conclusions which were drawn in the CVB reactor. So it is possible to transform results achieved in CVB into CFR, which can be representative of furnace condition.

3.2 Influence Of Molar Fraction Of Oxygen

In Fig. 7 it can be clearly observed that increment of oxygen concentration z_{O_2} in oxidizer results in linear increase of ΔT and decrease of τ_{ig} . Trials with propane are characterizing higher values of increment of temperature ΔT and, unfortunately also higher values of ignition delay time τ_{ig} in comparison with methane.

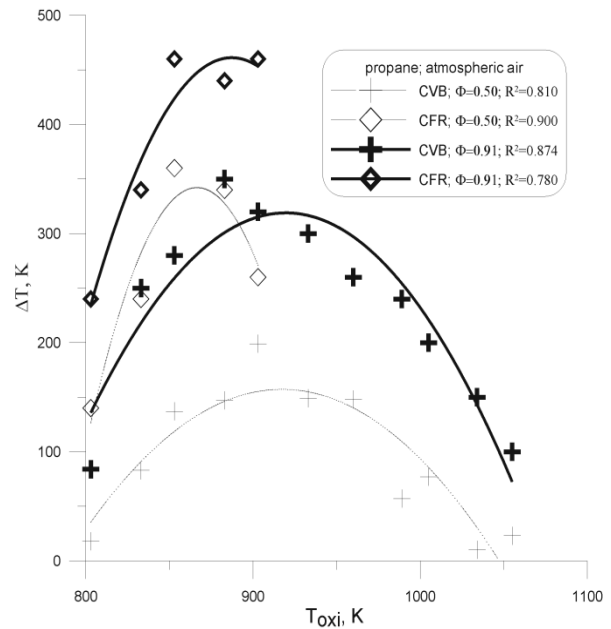

Fig.6. Dependence of increment temperature ΔT as a function of temperature oxidizer T_{oxi} : comparison of CVB and CFR results (atmospheric air)

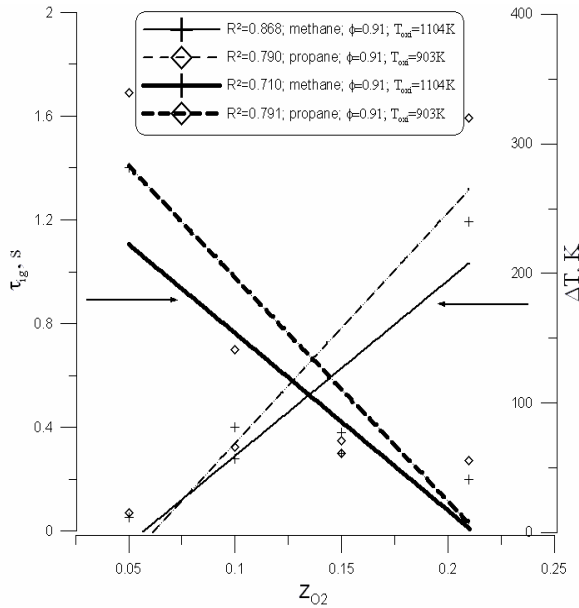

Fig.7. Ignition delay time τ_{ig} and temperature increment ΔT as a function of molar fraction of oxygen in oxidizer z_{O_2}

4. Conclusion

In order to achieve the minimum ignition delay time τ_{ig} (the maximum reaction rate) and the maximum of increment of temperature ΔT , the oxidizer has to be preheated to temperature T_{oxi} of about 1100K (in the case of methane) and 950K (in the case of propane). It seems that preheating of the oxidizer above this interval is unsubstantiated. Additionally it is important to keep interval of equivalence ratio approximately equal to $1.0 \div 1.1$.

Beyond this interval of T_{oxi} and ϕ in which $\tau_{ig} \rightarrow \min$ and $\Delta T \rightarrow \max$, analyzed parameters are going to increase (τ_{ig}) or to decrease (ΔT). It is mainly caused by the smaller level of gas concentration in constant pressure conditions

The optimum value of the oxidizer temperature is probably a function of the combustion chamber type, the intensity of mixing and other factors. However, experiments in CFR reactor present the possibility of saying that it is probably possible to transfer results from CVB reactor into a real installation.

5. Nomenclature

t, T Temperature [$^{\circ}C$], [K],
z Molar/volumetric fraction of gas.

Greek letters:

δ Uncertainty of measurement,
 σ Standard deviation,
 ϕ Equivalence ratio
 Δ Increment,
 τ_{ig} Ignition delay time [s].

Subscripts

au Autoignition,
ig Ignition,
oxi For oxidizer,
max Maximum,
min Minimum.

6. References

- [1] [1] Tsuji H., Gupta A.K., Hasegawa T., Katsuki M., Kishimoto K., Morita M., *High temperature air combustion. From energy conservation to pollution reduction*, CRC press 2003.
- [2] [2] Wilk R.K., *Low emission combustion*, Wydawnictwo Politechniki Śląskiej, Gliwice, 2002.
- [3] [3] Wünnig J.A., Wünnig J.G., *Flameless oxidation to reduce thermal NO-formation*, Prog. Energy Combust. 23 (1997), pp. 81-94.
- [4] [4] Milani A., *Diluted Combustion Technologies*, IFRF Combustion Journal, (2001), article number 200101.
- [5] [5] Wilk R.K., Szlęk A., Misztal T., Malczyk K., Zajdel A., *Badania procesu spalania oleju lekkiego przy wysokiej temperaturze*, Archiwum Spalania, 2 (2002), pp. 77-95 (in Polish).
- [6] [6] Weber R., Smart J., van der Kamp W., *On the combustion of gaseous, liquid and solid fuels in high temperature preheated air*, Proc. Combust. Inst., 30 (2005), pp. 2623-2629.
- [7] [7] Schaffel N., Mancini M., Szlęk A., Weber R., *Mathematical modeling of MILD combustion of pulverized coal*, Combustion and Flame 156 (2009), pp. 1771-1784.
- [8] [8] Bartok W., Sarofim A.F., *Fossil Fuel Combustion. A source book*, Wiley, New York, 1989.
- [9] [9] Werle S., Wilk R.K., *Self-ignition of methane in high temperature air*, Chemical and Process Engineering 28 (2007), pp. 399-412.
- [10] [10] Werle S., Wilk R.K., *Ignition of methane and propane in high-temperature oxidizers with various oxygen concentrations*, Fuel, 89 (2010), pp. 1833-1839.

7. Biography



Sebastian Werle

(www.itc.polsl.pl/werle), PhD is an Assistant Professor in the Institute of Thermal Technology at the Silesian University of Technology at Gliwice, Poland. His areas of interest include low emission (and high temperature air) combustion, biomass gasification and also thermal utilisation of sewage sludge. He is a Member of The Polish Section of the Combustion Institute. He has published more than 50 papers.